

# User Manual for NEPTUNE 4 MAX 3D Printer

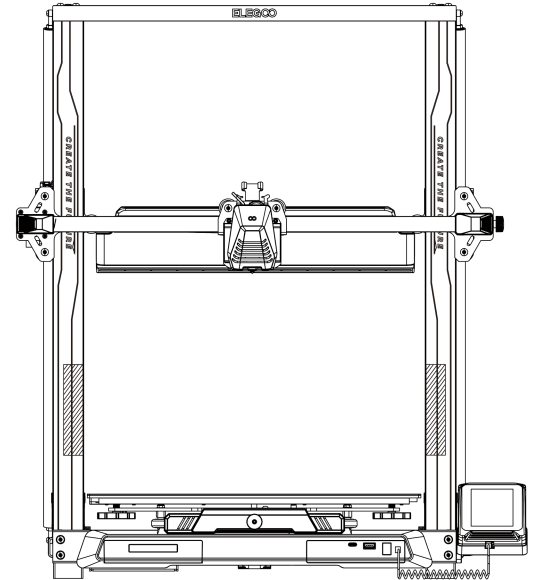

Pictures are only for illustration purposes. Actual production products may vary from images

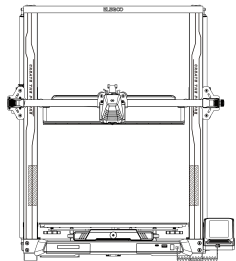

---

## Thank you for choosing the ELEGOO Product!

This User Manual has been provided for your convenience. Please read this instruction manual carefully before using your new printer, as the precautions, information, and tips can better help you to avoid the risk of incorrect product setup and usage.

For any questions or issues not covered in this manual, please contact us directly via our customer support email address: [3dp@elegoo.com](mailto:3dp@elegoo.com). The ELEGOO team is always ready to provide you with quality service.

To provide you with the best product experience, in addition to this manual, you can find supplemental information for the operation of your new printer via:

1. The USB Drive: The digital files include a copy of this manual and all required software.
2. The ELEGOO official website: [www.elegoo.com](http://www.elegoo.com) for related equipment operation, contact information, etc.

# NOTES

1. Do not place the printer in vibrating or other unstable environments, as the shaking of the machine will affect the print quality.
2. Do not touch the nozzle and heated bed when the printer is working to prevent high-temperature burn and personal injury.
3. After printing, please take advantage of the residual temperature of the nozzle and clean the filaments on the nozzle with the help of tools. Do not touch the nozzle directly with your hands during cleaning to avoid burning.
4. Please do product maintenance frequently, and regularly clean the printer body with a dry cloth to wipe away dust and sticky print material under the situation of power off.
5. 3D printers contain high-speed moving parts, so be careful not to get your hands caught.
6. Children must be supervised by adults when using the machine to avoid personal injury.
7. In case of emergency, please cut off the power directly.
8. Before leveling, homing or printing, ensure that the golden PEI is properly placed on the platform. Failure to do so may result in nozzle collisions with the magnetic sheet, causing damage to both the nozzle and the magnetic sheet.
9. It is essential to ground the machine during operation. Devices that are not grounded or improperly grounded inevitably increase the risk of electrical shock.
10. If the machine is not in use for a long period, please turn off the device and unplug the power cord.

# Troubleshooting Guide

A stepper motor of the X/Y/Z axis is not moving or making a noise when “zeroed”

- ① The stepper motor cable could be loose. Please recheck the wiring connection.
- ② The corresponding limit switch may not be triggering properly, please check whether there is any interference in the movement of the corresponding shafts and ensure the limit switch wiring is not loose.
- ③ Loose timing belt may result in rough motion or abnormal noise in the X/Y axis. It can be resolved by adjusting the tension of the timing belt using the rotary knob.

Nozzle Head Assembly is exhibiting Extrusion Anomalies

- ① Check that the extruder stepper motor cable is not loose or disconnected.
- ② Check whether the set screw of the extruder gear is firmly engaged to the motor shaft.
- ③ The heat dissipation of the nozzle assembly may not be enough, verify temperatures and check cooling fan operation.
- ④ For clogged nozzles, try first heating the nozzle to 230°C and pushing the filament by hand to remove a potential clog, or use a fine needle to unclog the nozzle tip while it is heating up.

Model does not Adhere to the Build Platform (PEI Sheet) or is Showing Warping

- ① The key to whether a model can adhere (stick) to the build plate is largely based on the printing of the first layer. When printing the first layer if the distance from nozzle to platform is more than 0.2mm, it will seriously reduce print adhesion
- ② Try setting the build model first layer option in Cura to [Brim] to improve first layer adhesion, this should also be used to reduce any cases whereby the edges of the printed model are warping or lifting off the build platform.

Model shows signs of Misaligned Printed Layers

- ① The travel speed of the Printer hot end assembly or Print Speed is set too fast. Please try to reduce the Print Speed
- ② The belts of the X/Y axis may be too loose or the synchronizer pulley is not secured tightly. Check these components.
- ③ The current to the Drive may be too low.

Severe Issues in Printed Model of “Stringing” or “Ringing”

- ① Insufficient retraction distance is causing issues, increase the retraction distance in Cura prior to Slicing.
- ② In many cases, if the retraction speed is too slow, you may need to set the retraction speed higher in Cura prior to Slicing.
- ③ When slicing your model, check the box for “Z Hop When Retracted” and set the “Z Hop Height” to about 0.25mm.
- ④ Print temperature may be too high, which can cause certain filaments to become sticky and stringy.

If the printing temperature is too high, it can cause the filament to become too fluid and sticky, resulting in poor 3D printing quality.

In this case, lowering the printing temperature slightly can help.



# Contents

Machine Parameters -----	1
Machine Component Diagrams -----	2
Packing List -----	3
Machine Setup & Installation -----	4
Display Screen Operation Introduction -----	9
Auto-Leveling Procedure -----	12
Model (Operation)Testing -----	13
Resume Printing Function -----	14
Software Installation -----	15
LAN (Network)Printing -----	17
Mainboard Circuit Wiring Diagram -----	19

# Machine Parameters

## Printer Specifications

Printer Type: FDM (Fused Deposition Modeling)

Maximum Build Volume: 420X420X480(mm<sup>3</sup>)

Print Precision: ±0.1mm

Nozzle Diameter: 0.4mm

Print Speed: 30~500mm/s

Regular Printing Speed: 250mm/s

Maximum Acceleration: 8000mm/s<sup>2</sup>

## Operating Temperature Specifications

Ambient Environment Temperature: 5°C~40°C

Maximum Temperature of Nozzle: 300°C

Maximum Temperature of Heated Bed: 85°C(ambient environment temperature: 25°C)

## Software Specifications

Slicer Software: Cura

Input File Format: STL, OBJ

Output File Format: G-code

Interface: USB Drive, LAN (Network), WIFI

## Power Supply Specifications

Input Power : 100-120V/220-240V; 50/60Hz

Output Power : 24V

## Physical Specifications

Machine Size: 658\*632\*740mm

Net Weight: 18.1kg

# Machine Component Diagrams

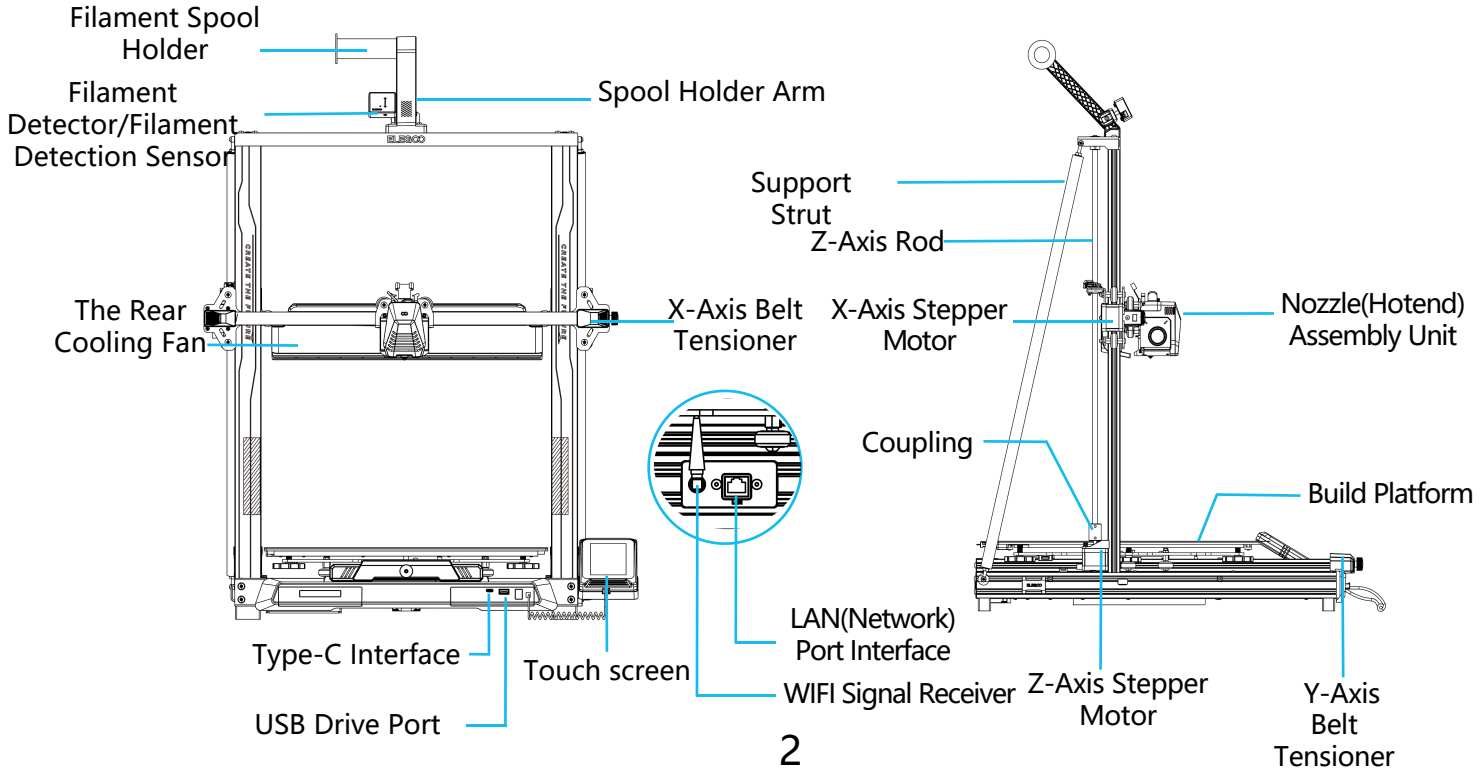

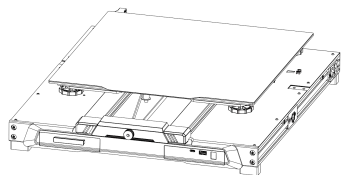

01 Base Unit

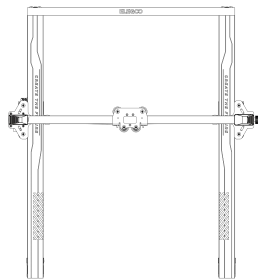

02 Gantry Frame Unit



Screen Support Block

03



Screen

04

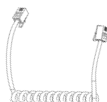

Spiral Cable

05



Spool Holder

06



Spool Holder Arm

07



Filament Detector

08

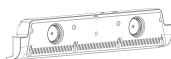

The Rear Cooling Fan

09



WIFI Antenna

10

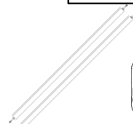

Support Strut

11



Printhead

12

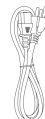

Power Cable

13

## Fasteners

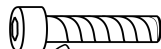

(HM5\*45) 4pcs



(PM4\*50) 4pcs



(PM4\*20) 5pcs



(PM4\*18) 2pcs



(PM3\*14) 3pcs



(PM4\*8) 3pcs



(HM4\*M3\*3) 1pc



(PM3\*8) 2pcs



(FW M5\*18\*1) 2pcs

## Packing List

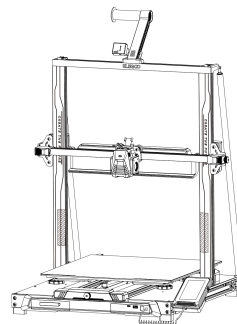

ELEGOO 3D Printer

## Tools

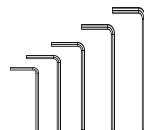
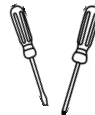
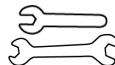

(1.5 / 2.0 / 2.5 / 3.0 / 4.0)

The above accessories shall be subject to actual products, and the pictures are for reference only.



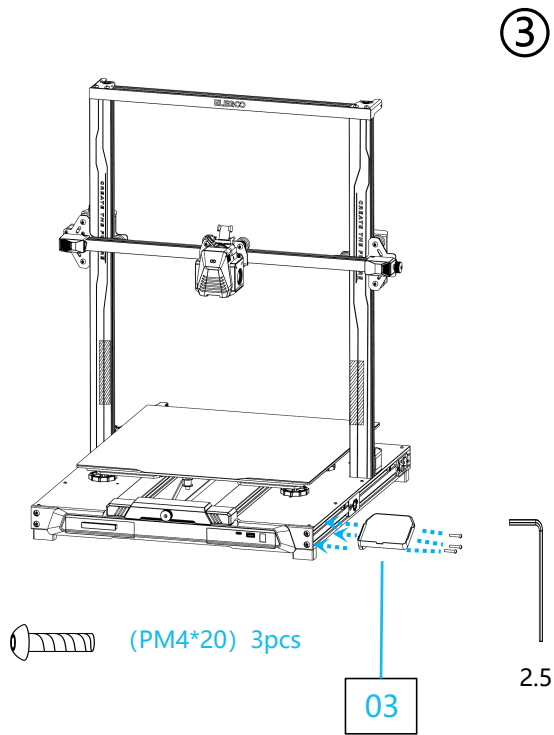

5

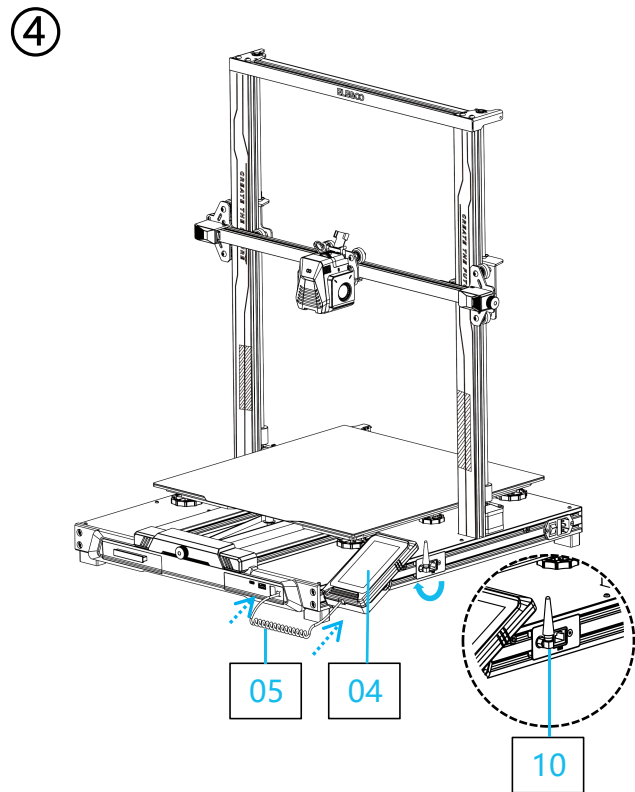

5

2.5  
(PM4\*18) 2pcs

(HM4\*M3\*3) 1pc

Filament Detection Sensor  
Installation:

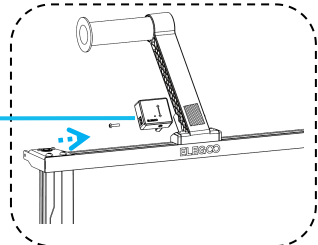

Cable clamp installation:

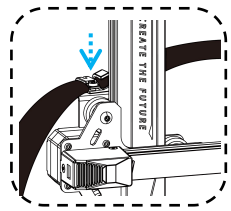

(PM4\*8) 1pc

When installing the cable clamp, you will need to first organize the cables and bunch them together before fully securing the clamp. Be sure to leave enough slack for the hotend to travel freely to each side and up and down.

6

6

(PM4\*8) 2pcs

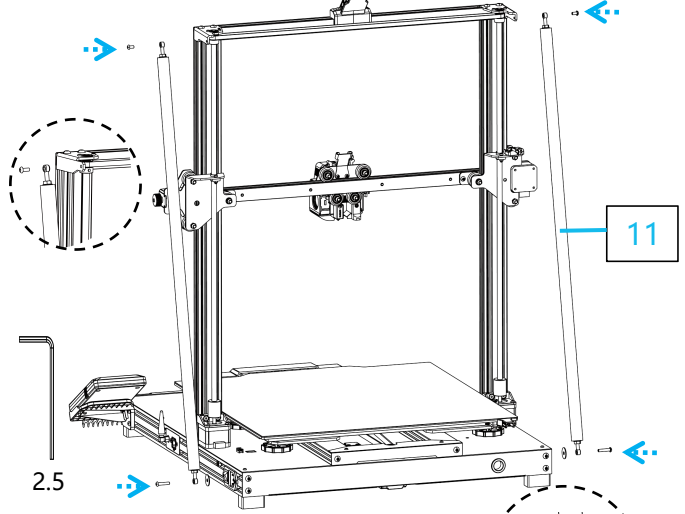

11

2.5

(PM4\*20) 2pcs

(FW M5\*18\*1) 2pcs

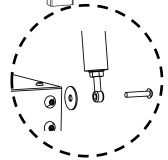

7

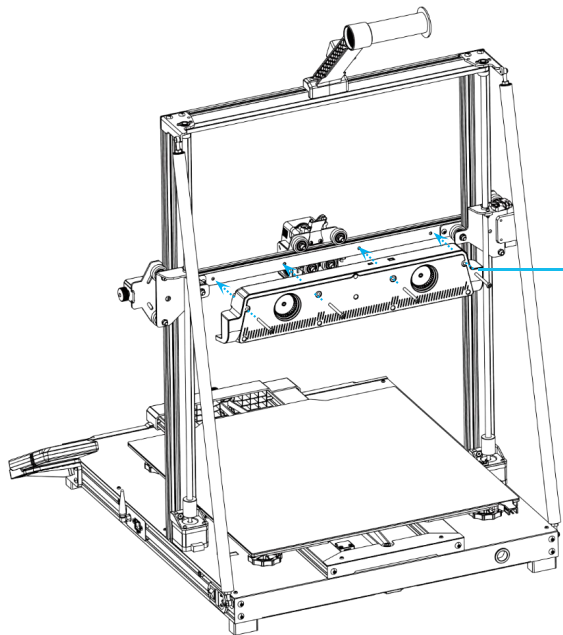

09

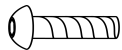

(PM4\*50) 4pcs

8

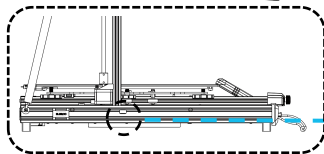
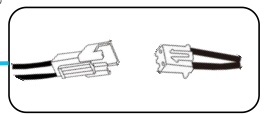
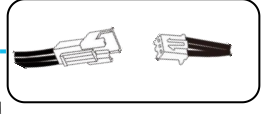
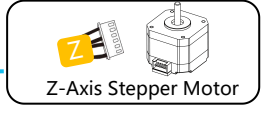
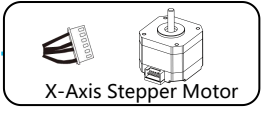
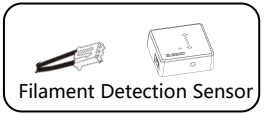
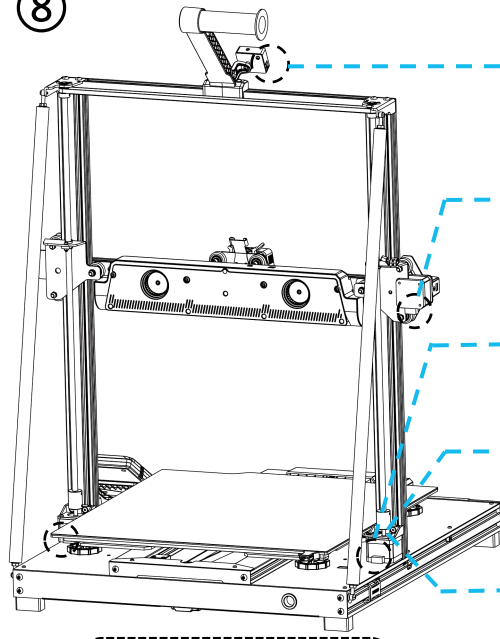

115V/230V selected by switch.  
Check the input voltage before use.

230V 115V

7



## Supplementary Introduction

### Special Case:

- The Y-axis slider plate is adjusted at the factory, but the machine's pulleys may be loose due to transportation. If the printing platform is shaky or loose, you can use an open-end wrench to slowly unscrew the hexagonal isolation column under the platform until the Y-axis slider plate slides smoothly without shaking!
- Similarly, you can adjust the hexagonal isolation column underneath the printhead if it wobbles or becomes loose. There are also corresponding isolation columns for the pulleys on both sides of the gantry that can be adjusted.

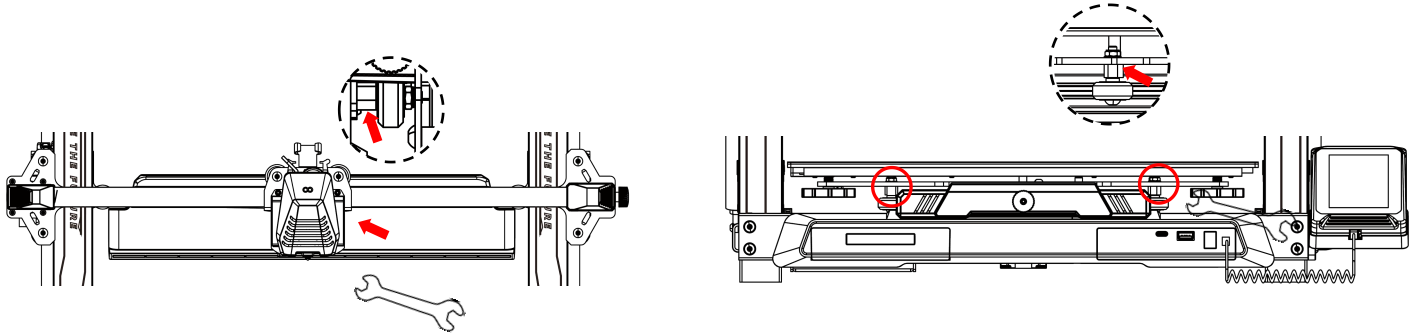

# Display Screen Operation Introduction

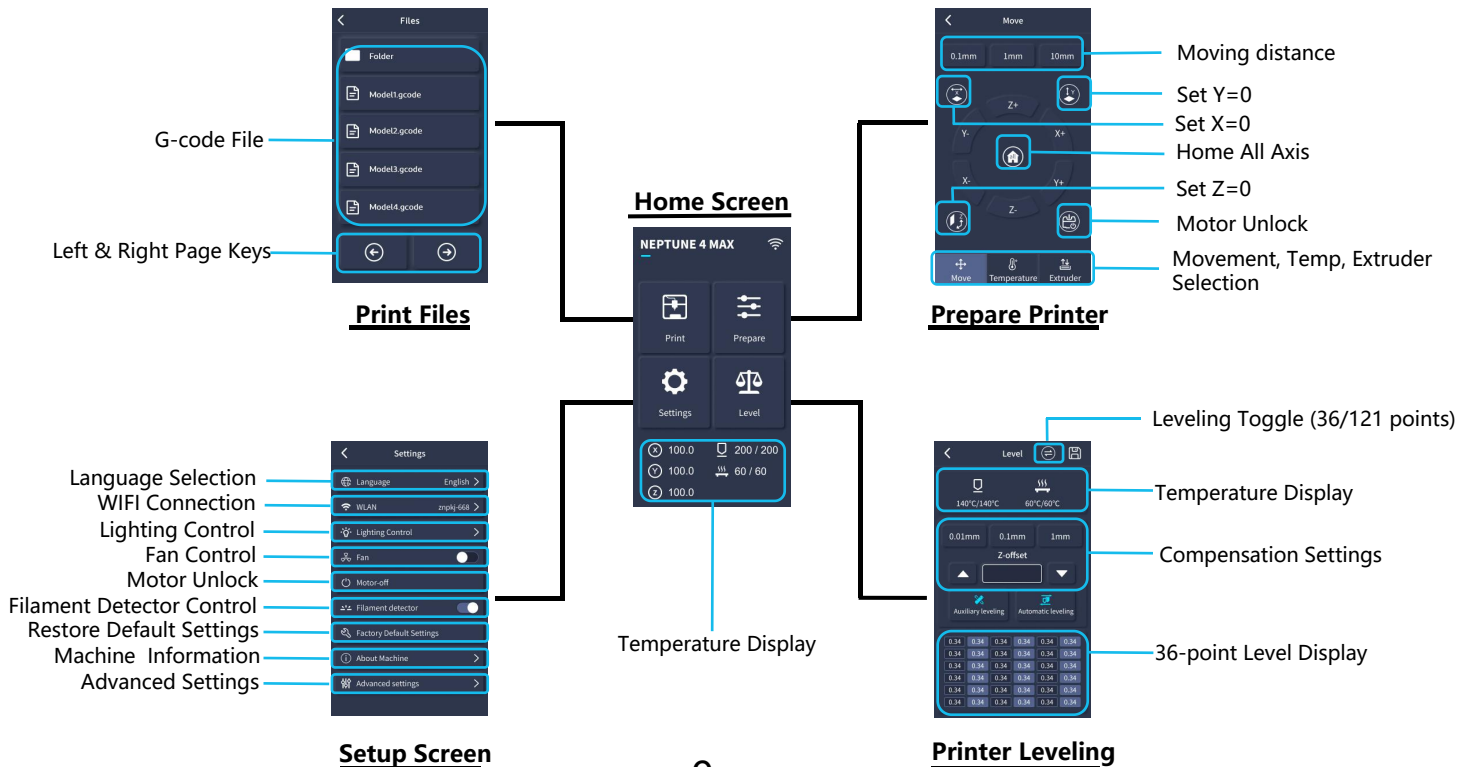

# Display Screen Operation Introduction

## Operation Of The Rear Cooling Fan:

From the Home Screen, select the Print option. Next select the Fan Icon in order to adjust the cooling fan operational settings during the printing process.

**NOTE:** The Rear Cooling Fan has three operational modes: Silent(60%), Normal(80%) & Sport(100%). Please select a mode appropriate to your printing needs as shown in photos below.

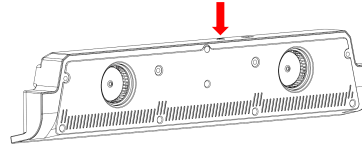
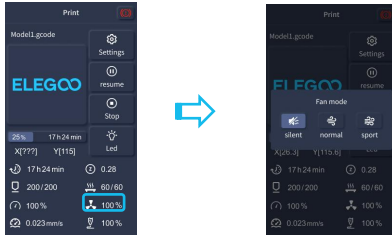

The Rear Cooling Fan is turned off when selecting the Silent mode

## Print Mode Introduction

- During the printing process, users can adjust the printing mode by clicking the speed icon.
- The three modes correspond to three different speed values, acceleration values, drive mute thresholds, and percentages of fan speed settings during printing.

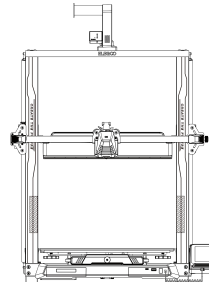
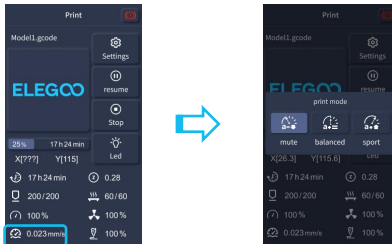

# Display Screen Operation Introduction

## Vibration Pattern Optimization Introduction

- It is recommended to perform vibration pattern detection after first use or after the machine is moved or parts are replaced. Users can select the vibration pattern optimization option in the advanced settings.
- Vibration mode optimization is performed on the X-Axis and Y-Axis respectively. Please do not shake the machine during the testing process and wait patiently for the testing to complete.





# Auto-Leveling Procedure

When first running the machine, the distance between the platform and the nozzle needs to be calibrated in the leveling mode, which is about the thickness of a piece of A4 paper .

Note that the leveling sensor only detects the metal platform plate, for example, replacing the glass platform for leveling will not produce detection effect, which will cause the nozzle to squeeze the platform.



- When the printer is powered on, select **[Level]** .
- Each axis of the printer automatically returns to the home position, after entering the leveling page, place a sheet of A4 paper between the nozzle and the platform, and adjust the height compensation values using the screen controls to increase or decrease the distance between the nozzle and the platform (P2), and slide the sheet of paper back and forth several times, until there is a slight amount of noticeable friction generated. At this point, the center point calibration will be completed. Next, select the auxiliary leveling option [  ], to calibrate the 6 corner points of the platform with the same sheet of paper by adjusting the hand-twisting nuts found under the heated bed, and once again sliding the paper until friction has been detected and the paper can be pulled out, but not slid under the nozzle. This will complete the auxiliary leveling calibration.
- After completing the manual auxiliary leveling process above, next select the automatic leveling option from the menu and your printer will begin the automatic calibration process. [  ]
- Your printer will enter a heating state during the automatic calibration process as the nozzle is heated to 140°C and the heated bed to 60°C (Please adjust the heated bed temperature to the recommended temperature of the filament you intend to use to ensure accurate leveling values) .
- After reaching the preset temperature, begin the 36-point automatic bed calibration.
- When completed, perform Z-axis compensation setting: Place an A4 paper between the print head and the platform. Adjust the compensation value by clicking, and gently slide the A4 paper. When the A4 paper can be pulled out but cannot be pushed in, the leveling is complete.
- Click the save icon to save.[  ]

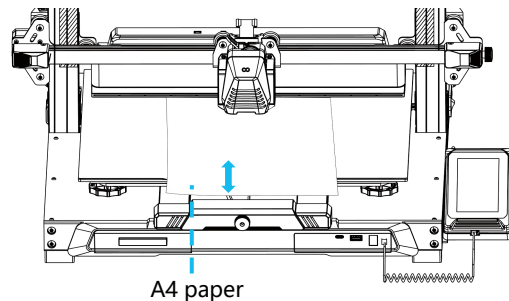
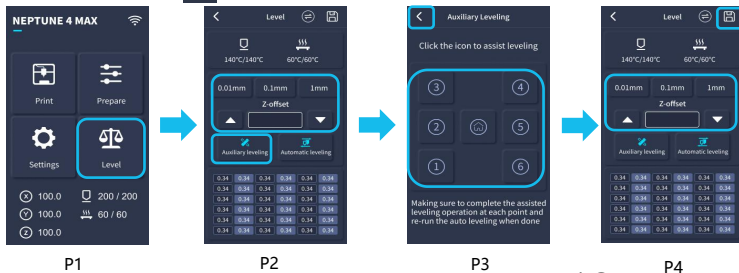

# Model (Operation) Testing

## Printhead Feeding Verification

1. First, insert the filament through the filament detection sensor and to the bottom of the Printhead assembly.
2. Choose [Prepare] > [Extruder] > [Load ] (the temperature of the nozzle will be automatically heated to 200°C.
3. After the nozzle reaches 200°C, choose the feed option to extrude filament material from the nozzle.
4. Clean melted filament off the nozzle and heated bed before printing.

**NOTE:** Filament with different hardness have different requirements for "spring" strength. The spring strength of the extruder can be adjusted with an Allen Wrench(within 2.0mm). When turning counter-clockwise, spring strength is increased, while spring strength is decreased when turned in a clockwise direction

## Printing Functional Test:

1. Insert the USB Drive into the printer's USB port.
2. Choose [Print] from the main menu and select the desired file.
3. When the nozzle and heated bed reach the required temperatures, the X, Y & Z axis will return to Zero (Home) and begin printing.

**NOTE:** When printing the test model, please observe the first layer printing and compare against the figure on the right. In cases A and C, the compensation settings are not properly adjusted. You can make compensation adjustments during printing to adjust the distance between the nozzle and the heated bed platform. In case B, the nozzle and the platform are at the ideal printing distance and can continue printing without any further adjustments.

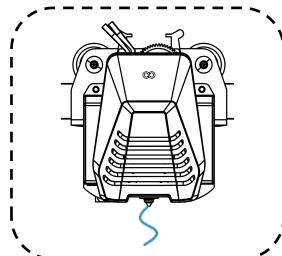

Normal Extrusion State

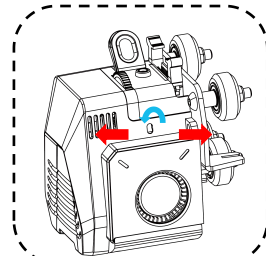

**Rotating the button counter-clockwise:** The extrusion force increases, which means that the filament is pushed out of the nozzle with more force.  
**Rotating the button clockwise:** The extrusion force decreases, resulting in a reduction of the force with which the filament is pushed out of the nozzle.

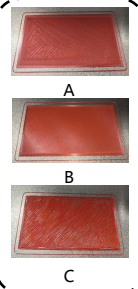
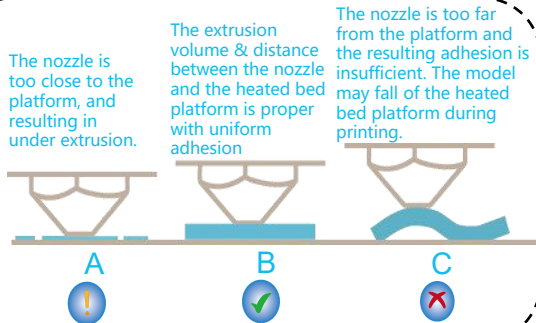

## Adjustment of nozzle height while printing

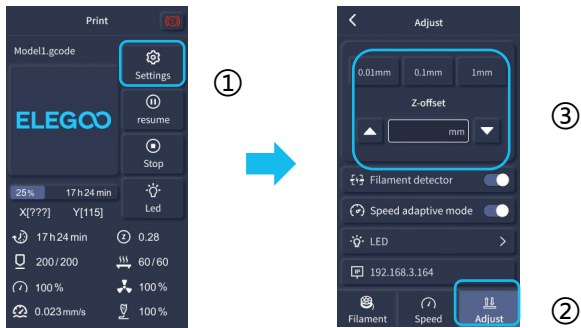

**NOTE:** While printing and following this procedure for fine-tuning the nozzle height, please ensure that you switch the moving distance to the smaller increment settings of 0.01mm or 0.1mm to prevent the nozzle from potentially dragging excessively along the heated bed platform (which can cause damage to the build plate) or to keep filament from “hanging” in the air.

## Resume Printing Function

### Power Loss Recovery:

1. Your printer, has features to continue printing following a sudden interruption or loss of power (an outage) or any accidental events (aka “switching-off” power), and this function does not need to be set manually.
2. Once power has been resumed to the printer, simply press the “Resume” option to continue printing.

NOTE: The PEI metal build plate has better overall adhesion when it is fully heated. If the power has been “Off” for too long, the model may become easily dislodged or fall off the PEI plate very easily. In such event, the Resume Printing Function will not be able to continue.

### Filament Detection:

When the sensor detects that filament is not present, this function will inform you to replace the filament before continuing an active print, in order to prevent a print failure due to insufficient filament material.

# Software Installation

**TIP: We recommend copying the entire contents of the included USB Drive to your local computer for easier access to all of its files.**

The included “Slicer” Software program is a modified version of the Cura Open Source Slicer software that is publicly available. While you can always use any version of Cura, we strongly urge you to use the ELEGOO version of Cura in order to ensure maximum tested compatibility with your specific ELEGOO printer.

## Software Installation Procedure:

1. Open the attached USB Drive and navigate into the path: \Software and Software Drivers folder \ELEGOO Software folder and “double-click on the ELEGOO Cura application to begin the installation process.
2. Continue by following the prompts in the installation process specific to your system.
3. Finally, select the corresponding ELEGOO printer model as shown below to complete the settings process.

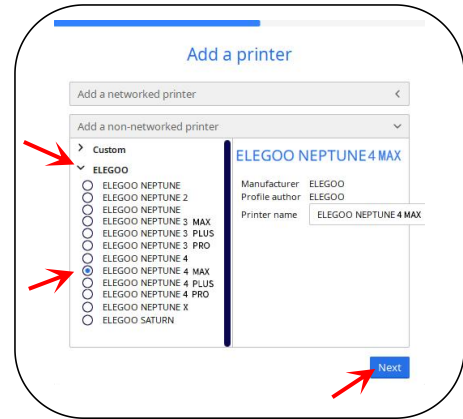
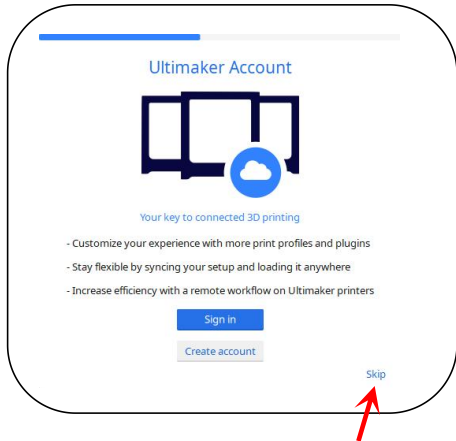



# Instructions for Software Usage

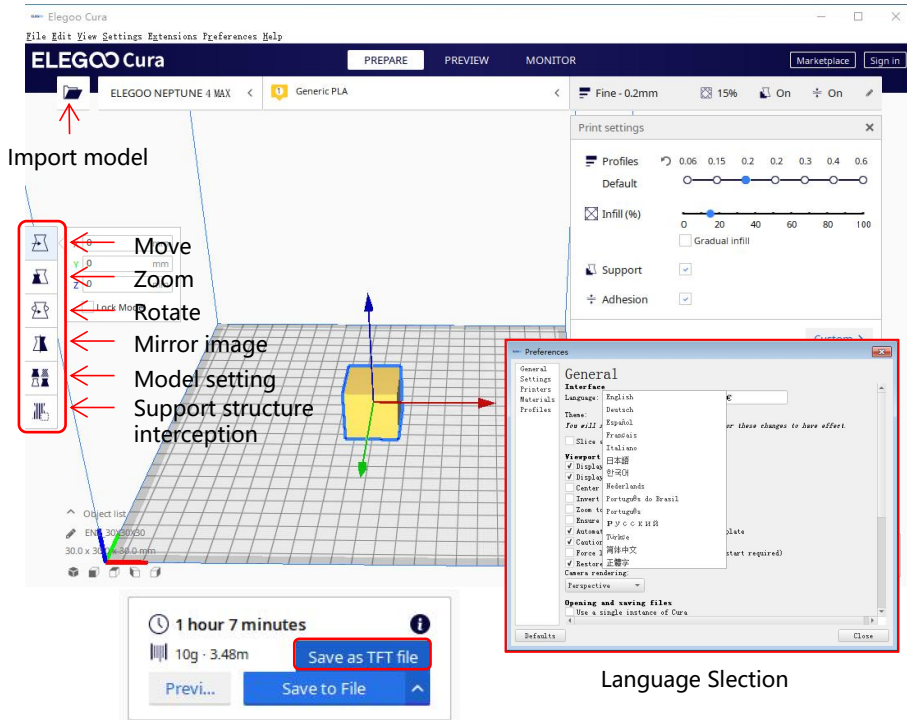

Preview Image Function

Language Selection

## Other Software Usage Tips:

1. Use the middle mouse wheel to zoom the viewpoint (in and out) and hold down the middle mouse wheel to move the platform position on screen.
2. Press and hold the right mouse button while moving your mouse to pivot around your model's viewpoint.
3. Clicking the right mouse button will bring up a pop-up selection options menu.

## Model Settings:

When printing multiple models, you can configure individual slice settings for the specified model.

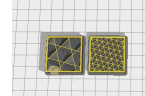

## Support Structure Interception:

This feature enables you to define an intercept region on your model to inhibit the generation support material.

## Preview Image Function:

G-code files saved in the TFT file format can use the printer's preview capabilities to display a thumbnail image of the model.

## Language Selection:

You can change the language by accessing the Preferences in the top menu bar. Once you have selected the desired language, you will need to restart the slicing software to apply the changes.

# LAN(Network) Printing

The device supports WIFI and network cable connection. After the connection is successful, check the IP address on the screen, and enter the IP address through the browser to access the machine.

**NOTE:** Your Printer and Your Local Computer can only be connected to the LAN (Network) over the same network segment. You should ensure that the network wiring port on the Printer is connected, otherwise the access will fail.

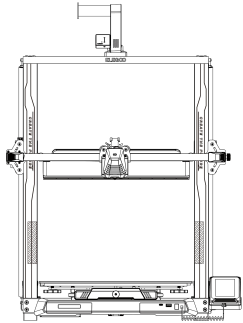

LAN(Network) Interface



WIFI Connection

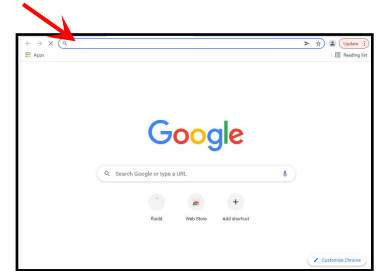
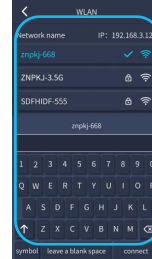
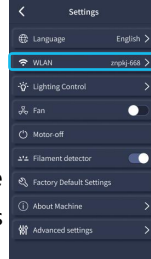
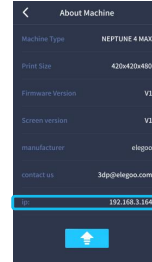
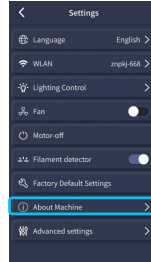

**NOTE:** Using Google Chrome (on your local computer), you can enter the IP Address listed on your Printer' s Display to access the Printer directly (eg. <http://192.168.211.164>). Following entry of this address, press the "Enter" key to access the Printer' s Network page.

**NOTE:** Upon the successful access of the Printer' s Network Interface, you will be presented with the following screen.

The image shows a screenshot of the PrusaSlicer software interface. Five red rectangular boxes highlight specific sections of the interface:

- Movement Control:** Located in the top-left, it features a grid of icons for axis movement (Home, Move, Rotate) and sliders for Speed and Pressure Advance.
- Fans and Output:** Located in the middle-left, it includes a slider for the Print Fan and a checkbox for the Fan 1.
- Printer Limit:** Located in the bottom-left, it shows sliders for Max. Velocity and Acceleration.
- Temperature Display:** Located in the top-right, it displays a graph of temperature over time for the Hotend and Bed.
- Console Display:** Located in the middle-right, it shows a log of G-code commands being executed.
- Task List:** Located in the bottom-right, it shows a list of tasks to be printed.

**Movement Control:** Provides the ability to control the movement of the printer' s printhead along each axis of control, and can set compensation following the leveling process.

**Fan and Output:** Provides the ability to control the printhead Fan and to turn Lighting (on/off).

**Printer Limit:** Sets the maximum acceleration control of the printer, normally there' s no need to modify.

**Temperature Display:** Displays the Printer' s temperature(s) and heating status. This also provides controls for the preheating of the printhead temperature as well as the heated bed temperature.

**Console Display:** Shows G-code commands executed and allows for manual G-code to be sent to Printer.

**Task List:** You can drag the G-code file of the ELEGOO Cura slicer to the task list here for Printing.

# Mainboard Circuit Wiring Diagram

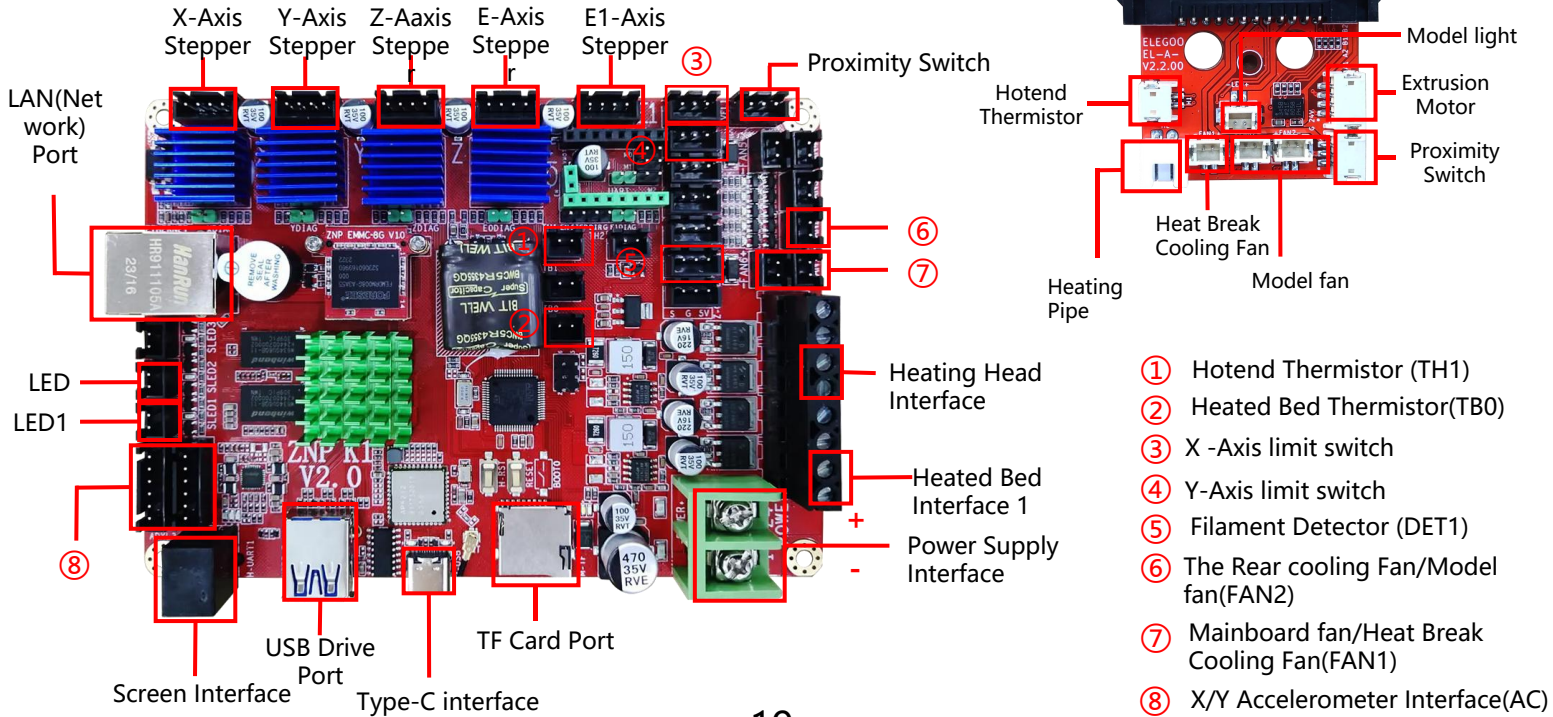

# After-sales service registration card

Date of purchase: \_\_\_\_\_

Place of purchase: \_\_\_\_\_

Printer: \_\_\_\_\_

S/N: \_\_\_\_\_

Fault description:

---

---

---

Contact: \_\_\_\_\_

Address: \_\_\_\_\_

Phone number: \_\_\_\_\_



ELEGOO official website: [www.elegoo.com](http://www.elegoo.com)

